

TOP GUN PRO HELI

RAPIER250

*Electric Powered
6 channel RTF
RC Helicopter*

Rapier 250

Specification:

Type: RTF Electric 3D Heli
Transmitter: 2.4ghz 6CH with idle up / 3D function
Length: 420mm
Height: 161mm
Main Rotor Diameter: 438mm
Main rotor type: 215mm Carbon blades
Tail Rotor Diameter: 105mm
Gyro: Etronix Head Lock Gyro
Brushless Speed Controller: 15amp
Battery: 7.4V 850MAH 15c LiPo
Motor: Brushless 4800KV
Servo: 7g x 4pcs

Rapier 250 Part No. TGH001

INSTRUCTION MANUAL

WWW.TOPGUN-RC.COM

Rapier 250

ELECTRIC POWERED 6 CHANNEL RTF RC HELICOPTER



All pictured Helicopters are of the 450 version

INSTRUCTION MANUAL

CONGRATULATIONS ON PURCHASING THE TOP GUN PRO HELI RAPIER

WARNINGS BEFORE USE

As the user of this product, you are solely responsible for operating it in a manner that does not endanger yourself and others or result in damage to the product or the property of others. This model is controlled by a radio signal that is subject to interference from many sources outside your control. This interference can cause momentary loss of control so it is advisable to always keep a safe distance in all directions around your model, as this margin will help to avoid collisions or injury.

1. Never operate your model with low transmitter batteries.
2. Avoid operating your model in the street where injury or damage can occur. Always operate your model in an open area away from cars, traffic, or people. Never operate the model out into the street or populated areas for any reason.
3. Carefully follow the directions and warnings for

this and any optional support equipment (chargers, rechargeable battery packs, etc.) that you use.

4. Keep all chemicals, small parts and anything electrical out of the reach of children. Moisture causes damage to electronics. Avoid water exposure to all equipment not specifically designed and protected for this purpose.
5. Never lick or place any portion of your model in your mouth as it could cause serious injury or even death.
6. This RC helicopter is not a toy! Incorrect operation may cause serious injury or damage. If you are a novice pilot we strongly suggest that you should find an experienced pilot in RC helicopters to assist you.
7. It is absolutely necessary to read the manual of the helicopter before operation, it is mandatory to check all control systems and mechanical linkages for proper operation before every flight. Safety first!

8. Since the helicopter can fly very fast, it may cause potential danger, so the choice of the flight field is of great importance.
9. Do not fly near crowds, high voltage cables or trees to ensure the safety of yourself and others.
10. Do not fly in bad weather such as rain or thunder storms to ensure the safety of yourself.
11. It is suggested to fly at an open field for beginners, and fly with a training set to practice

BATTERY & CHARGING WARNING

It is important that you only charge the included 3S 11.1V 2200mAh Li-Po Battery with the included 3S 11.1V 1.0-Amp Li-Po Balancing Charger. Your battery is equipped with special Charge Protection Circuitry and Balance Charge Leads with connector that are only compatible with this charger. Attempting to charge the battery using another Li-Po charger or non Li-Po compatible charger could result in serious damage.

Please familiarize yourself thoroughly with the Battery Warnings and Guidelines section before continuing. *A detailed Guideline and Safety page on handling and charging LiPo batteries can be found at the rear of the manual.* The included 3S 11.1V 1.0-Amp Li-Po Balancing Charger will charge a near fully discharged (not over-discharged) 3S 11.1V 2200mAh Li-Po battery in approximately 1.5-2.0 hours. In some cases the charge time may be shorter depending on the actual amount of capacity left in the battery after a flight.

NEVER charge the battery unattended.
NEVER charge the battery by flammable material.
ALWAYS charge the battery in a tin or LiPo safe sack, away from combustible material to contain any possible fire risk.

NOTICE

The Li-Po battery included with your Rapier 3D will arrive partially charged. For this reason the initial charge may only take approximately 30-50 minutes.

The charger requires up to 3-Amps of 11.515 Volt DC input power that can be supplied by the optional AC to 12V DC, 3-Amp Power Supply for convenient charging anywhere an AC outlet is available. **NEVER** attempt to power the charger from an AC outlet without the use of a proper AC to DC adapter/power supply.



QUICK START GUIDE

TRANSMITTER & RECEIVER BIND INSTRUCTIONS

Please Note: The Rapier features automatic binding when the TX & RX are turned on. If you happen to be flying with a friend or colleague using the same radio system, please ensure that one is properly bound before binding another, as it could be possible for one TX to be bound to two Rapier receivers if by chance they are turned on at exactly the same time.

OVERVIEW

We have put together a quick start guide to get you up and running with your Rapier ASAP. If you are not a novice you can be up and running with in the hour.

These models are set up and factory tested to fly out of the box. Minor trimming may be required and some basic set up tips are advised for the more advanced pilot.

Out of the box your Rapier will hover and in the 3D Fly mode is more than capable of basic 3D, with a tweak or two to the settings

it is even capable of the more advanced 3D. We have tested many of them out of the box and have them flying inverted as well as flipping about with no changes at all to the out of the box set up.

If you are a first time modeller it is recommended you use a flight simulator to familiarise your self with the basic controls, the RealityCraft RC Helimaster SIM is a good starting point.

Once you are familiar crack on with our quick start check over and 10 step check:

1. First of all set up your flight battery to be installed in the machine using the supplied Velcro to hold the battery in position in the battery tray, make sure it is secure and not likely to come loose during flight.
2. Put the battery on charge using the supplied balancing charger, this should take no more than an hour (**FOLLOW ALL SAFETY GUIDES**)
3. Put the 8AA batteries in to the transmitter (not supplied).
4. Check all the switches on the transmitter are in the away / up position when ever you turn it on and the throttle is at the low position, the most

important note here is to ensure the FLY switch in the up / away position or NOR. The transmitter has a safety feature to stop it turning on at full throttle but treat it like a loaded weapon when the model and the heli are turned on.

5. Check the model over paying important attention to make sure all ball links are connected, also check the main and tail blades as well as giving the model a good once over for anything obvious
6. Put your fully charged battery back in to place and secure it in the model with velcro.
7. Put the throttle at the low position and turn on the transmitter.
8. Now plug the battery into the speed controller and put the canopy back on – be careful as the helicopter is now armed and dangerous
9. Put the model in a safe place to take off and take a few step back and test the control surfaces, right aileron for right aileron, backward for backward and left tail command will send the lower tail blade turning clockwise when viewing the model from behind, although this is not an issue out of the box it is worth a quick sanity check each time you go out to fly.
10. Slowly lift off and enjoy.

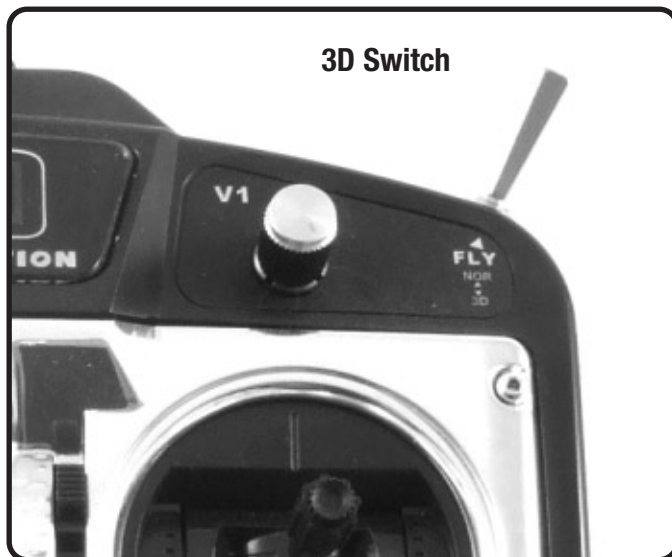

ADVANCED SET UP TIPS

When flying inverted or flying around you may want to increase the throttle at the mid point with the FLY switch in the 3D position.

The basics of flying inverted involve introducing negative pitch while increasing the throttle, this is unlike the normal throttle setting (in the up / away position) where when you bring the stick to the

bottom of the box the throttle is reduced. This introduction of negative pitch and more power will mean you can start to fly the model inverted, roll, loop and general fly the model around with a little more vigour.

When you get to the stage where you want to do more 3D flying you may want to introduce more throttle a the mid stick throttle position.

We would recommend to use the following throttle settings, 100% at low stick, 80% at mid stick and 100% at high stick position. To achieve this you will need to follow the next steps:

NOTE: disconnect the three bullet connectors between the motor and ESC.

1. Flip dip switch EXP to the ON position, with dip switch PLT/PITCH and RUDD/GYRO SENS (dips 9 and 10) in the off position.
2. Now turn the rotational dial on the front top right of the transmitter clockwise to the + position.
3. Now turn the dip switch EXP (dip 8) to the OFF position and turn the transmitter off and on.

COMMON REPLACEMENT PARTS:

Should you be unfortunate enough to bump you new Rapier you will be pleased to know there is a full range of well priced spares available. Should you have a crash or an impact be sure to check the following to get the best from the model and to keep it and you safe from harm. If you have any wobbles you can normally relate it to these spinning parts:

- Main blades
- Tail Blades
- Main rotor shaft
- Feathering spindle
- Tail output shaft
- Boom

The Rapier is a great model offering some amazing performance and great value. Here are a couple of things to 'DO' to make sure you can enjoy it for as long as possible:

- Do check the model over before and after every flight, pay special attention to the blades and control rods / balls.
- Check for a full charged transmitter and main battery pack.

DETAILED SET-UP & FUNCTION GUIDES

HELICOPTER LIPO BATTERY CONNECT

1. First turn the transmitter on and lower the throttle/collective stick completely, also make sure the FLY mode switch is in NOR or away position.



2. Once the battery has been properly positioned, fasten the hook and loop strap around the battery for added security. Then, plug the battery into the battery leads of the ESC.

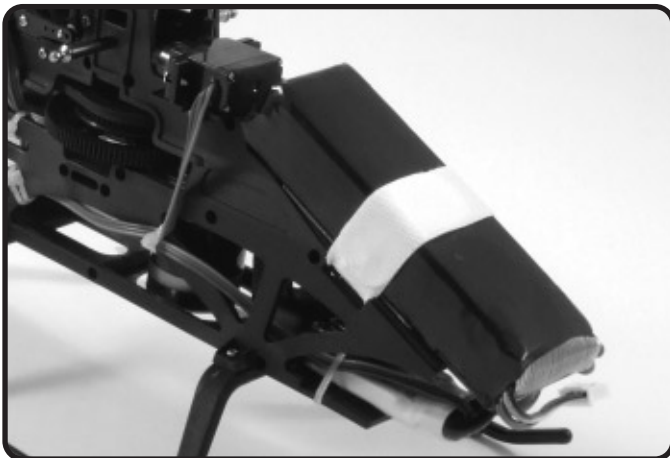

CONTROL TEST

Although each Rapier 3D is control tested at the factory, it is a good idea to test the controls prior to the first flight to ensure none of the servos, linkages or other parts were damaged during shipping and handling. ***Before proceeding, disconnect the three bullet connectors between the motor and ESC. It is not safe to perform the control test with the motor connected to the ESC.***

Position the helicopter to view it from the left or right side. Move the left-hand stick up and down to check the collective pitch control.

When the stick is pushed up, the swashplate should raise, increasing the pitch of the main blades.

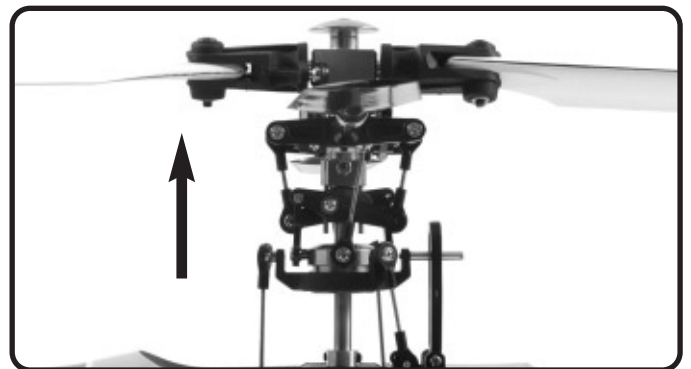
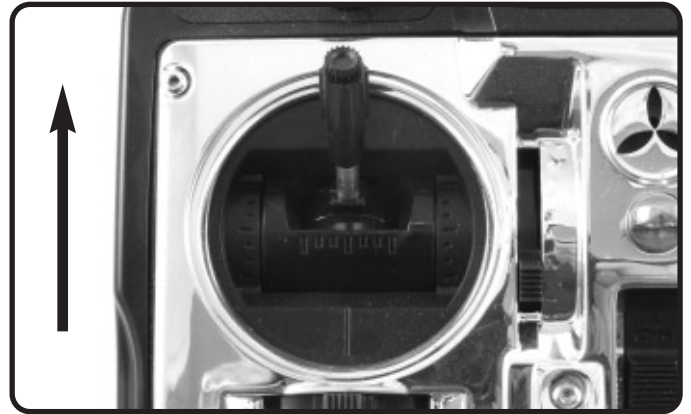

With the stick pulled back down, the swashplate should lower, decreasing the pitch of the main blades.

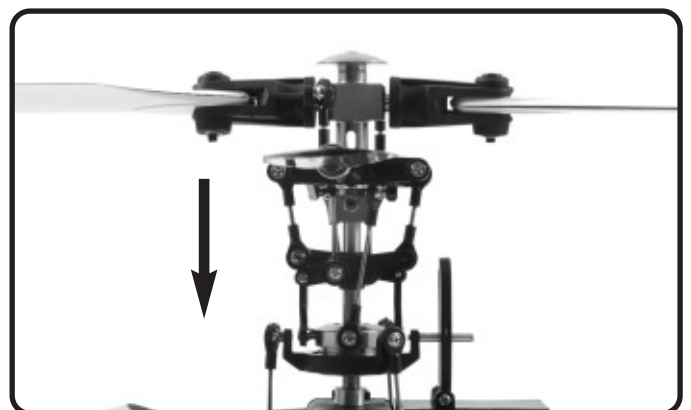

Again viewing the helicopter from the left or right side, move the right-hand stick forward and aft to check elevator pitch control. When the stick is pushed forward, the swashplate should also tilt forward.



With the stick pulled back, the swashplate will tilt toward the rear.

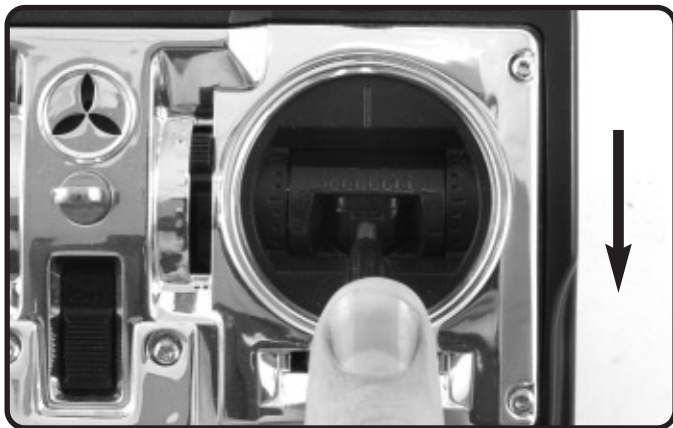

While viewing the helicopter from the rear (tail boom toward you), move the right-hand stick left and right to check aileron roll control. When the stick is pushed to the right, the swashplate should also tilt right.

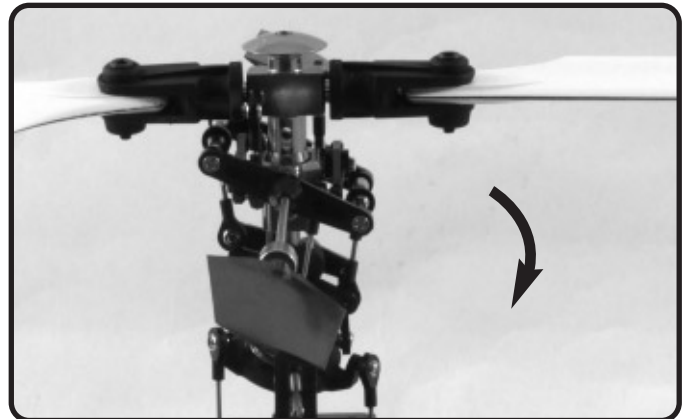
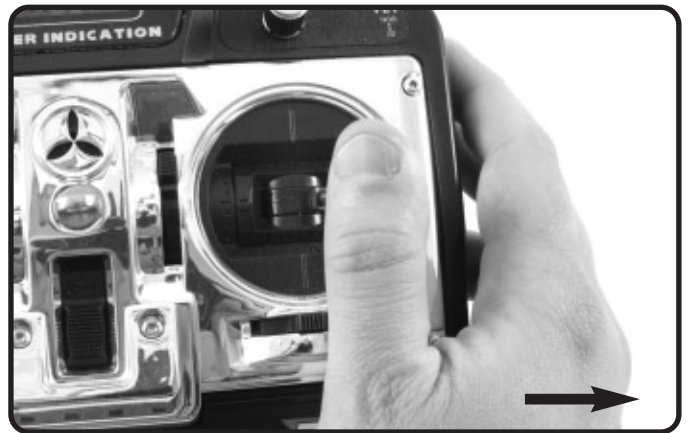

With the stick pushed left, the swashplate will tilt to the left.

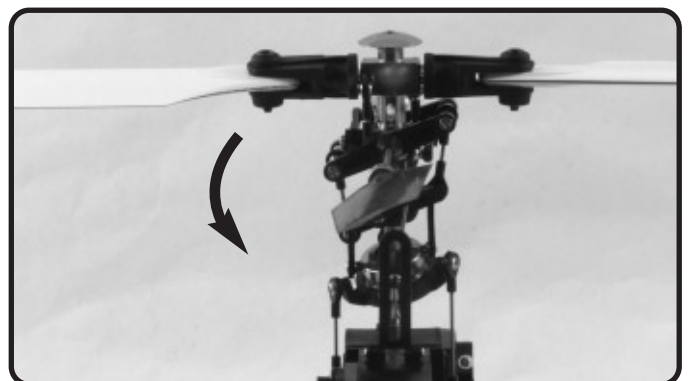

While viewing the helicopter from the rear (tail boom toward you), move the left-hand stick left and right to check rudder/tail rotor pitch control. When the stick is pushed to the right, the tail pitch slider should move to the left.

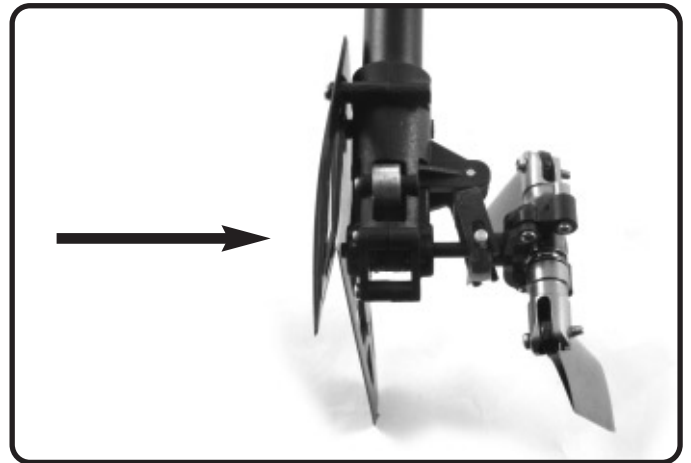
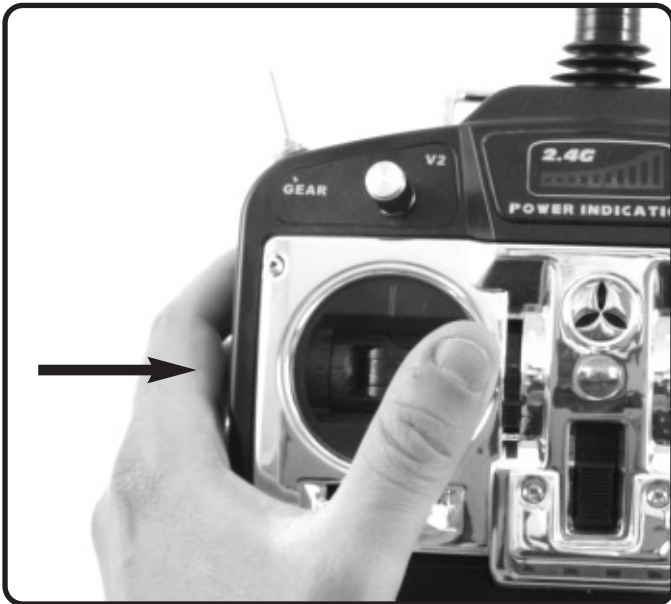

GYRO ADJUSTMENT AND RUDDER MIXING.

With modern day gyros you have the option to adjust the gain (the amount of correction it gives) both up and down. The more you have the more stable the tail and easier it is to control, but if you have too much the tail / nose can wag. Out of the factory there is no need to adjust anything, however if you make tweaks, change the servos or change the head speed you may need to adjust this.

Another feature of this transmitter is rudder mixing which compensates for RPM changes but with the Gyro in this machine you won't be needing that so when following the instructions below please ensure dial V1 in the top right is turned anti clockwise to the negative value position.

1. Flip the RUDD MIX ./GYRO SENSE dip to the on position.
2. Turn the V2 dial, top left of the transmitter to the 12 O'clock position, this is approximately 50% and should be a starting point, if its too lively, turn it up (clockwise) and if it wags turn it down (counter clockwise). It is possible to adjust this on the bench or whilst flying (obviously once landed).

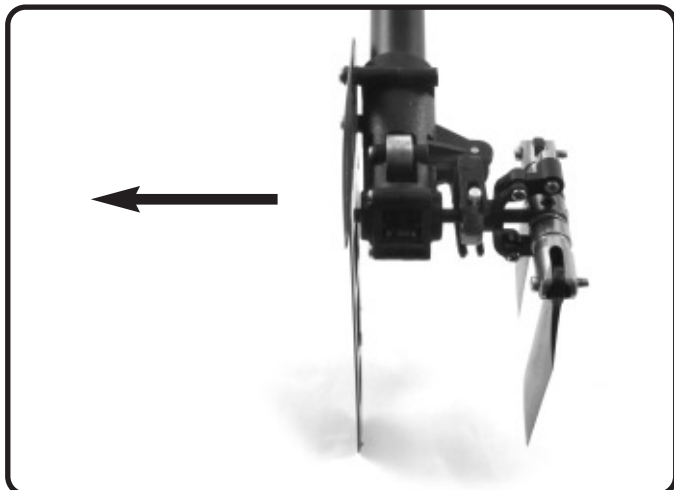

With the stick pushed left, the tail pitch slider should move to the right.

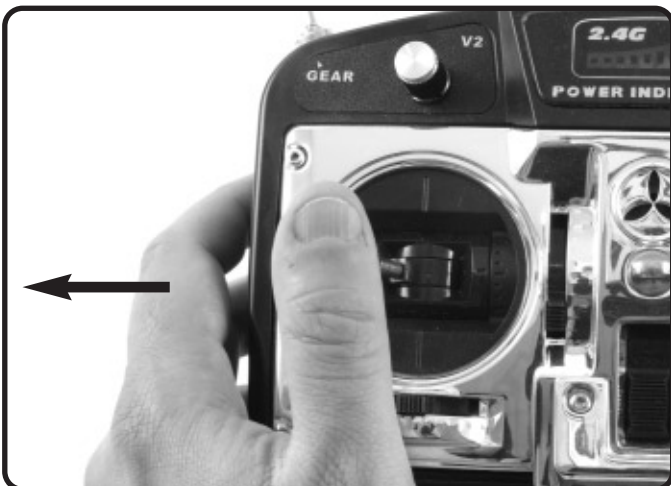

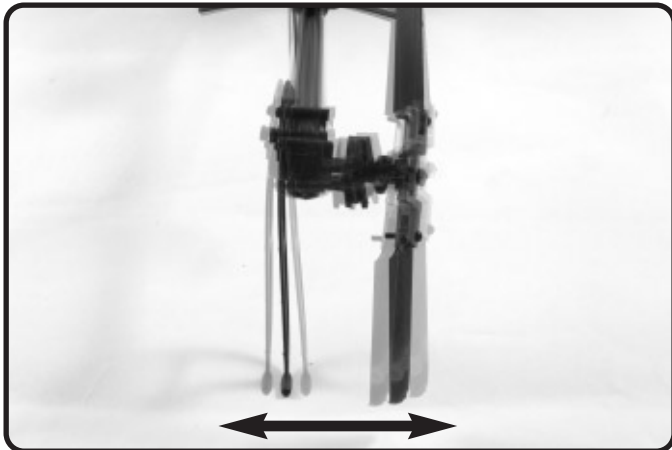

3. When the required gain is achieved flip to DIP back to off.

MAIN ROTOR BLADE TRACKING ADJUSTMENT

Caution: Be sure to maintain a safe distance from the helicopter (20-25 feet) when tracking the main rotor blades. Blade tracking is a critical element to the flight performance of just about any helicopter, Main rotor blades that are out of track may cause vibration, instability, and loss of power due to increased drag. Although the main rotor blades of each Rapier 3D helicopter are tracked at the factory, minor adjustments to blade tracking may be required after blade changes, linkage adjustments or repairs. To check main rotor blade tracking and make any required adjustments, please note the following tips: Before proceeding with the test flight of a new model, or any model to which changes or repairs have been made, be certain that the main rotor blades have been properly installed and secured. The main rotor blade mounting bolts should be tightened so that the blades can pivot in the blade grip when moderate pressure is applied. Never allow the main rotor blades to swing freely in their grips.

After powering the model on and allowing the ESC and gyro to properly arm and initialize, bring the main rotor blades of your Rapier 3D up to speed. You can check the blade tracking either on the ground or in the air at approximately eye level. It might be a good idea to have an assistant on hand to help sight the blades. Again, be certain to maintain a safe distance of (20-25 feet) from the helicopter when checking the tracking of the main rotor blades.

Once the main rotor blades have been brought up to speed, note which blade is running low and which blade is running high (by the colored tracking tape). Helicopters with variable pitch on the main rotor blade all have pitch control links. You only need to turn the control link of the higher or lower blade to bring it in line. With the Rapier the adjustment to the main blade holder is on the trailing edge, if the blade you are adjusting is the high blade in the tracking exercise detailed above then you need to bring this down, so unscrew the ball link to the trailing edge by 1 turn and remeasure, if you need further adjustment and go to the lower blade and bring this up by screwing the ball link on the linkage rod by one complete turn. When making a rod longer ensure you leave enough thread into the ball link. So as an overview the best way is to adjust both pitch control link is at the same time.



If the main rotor blades are still out of track, you need to adjust another blade, and repeat the process to check the blade tracking and make adjustment until both blades run in track. With proper adjustment, the helicopter will fly stably and smoothly.

TRANSMITTER PITCH ADJUSTMENT.

The pitch travel and factory set up for this model is perfect for most people's tastes right out of the box and should not need changing. However, should you be experienced or wish to tweak this or should you need to change this at a later date do a rebuild then the following steps can be taken to check and correct / check the pitch range.

Before starting this process please disconnect the motor from the speed controller:

1. Check the speed controller is not connected to the motor to avoid any unwanted spinning up of the main blades.
2. You can now turn the transmitter and model on.
3. With the FLY switch in 3D mode (towards the pilot) put the pitch stick to the middle, this will centre the servos, please make sure all servo arms are centred and horizontal, also running up

the swash plate to the control arms these too should be horizontal / flat. In turn this should give 0 degrees pitch out put on the blades, if needed adjust the rod links equally each side to get it level – this is the first check and a great bench mark for a rebuild.

PITCH ADJUSTMENT

1. Check the speed controller is not connected to the motor to avoid any unwanted spinning up of the main blades.
2. Flip dip switch PLT / PIT to the ON position, this will enable the pitch travel adjustment function
3. in FLY mode Normal or the away position, both of the dials V1 and V2 function, V2 will adjust the whole range available, i.e. +/-12 degrees down to -0 and dial V1 will just lower the bottom end, adjust as needed.
4. Flick in to FLY 3D mode and the V2 dial is the only one that functions allowing top and bottom pitch adjustment only.
5. Once complete flick the DIP switch PLT/PIT to off and restart the model and TX.
6. Once set up is complete reconnect the motor.



Please Note. Some parts will appear the same but listed as Sport or Pro. Pro Rapier features all Aluminium Head Assembly)

PARTS LISTING

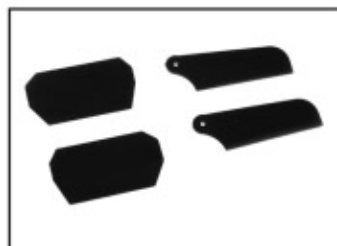

Paddle and Tail Blade
TGH0201

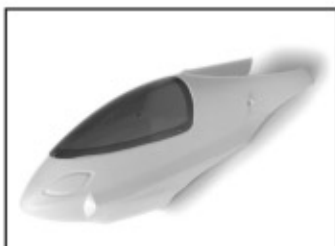

PVC Canopy (Sport)
TGH0202



Main Frame Set
TGH0203



Canopy Mount
TGH0204



Tail Driven Set
TGH0205



Belt Pulley Wheels
TGH0206

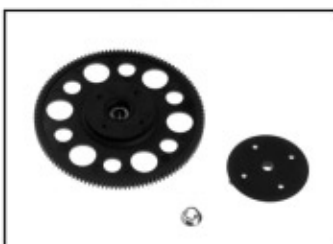

Main Gear Set
TGH0207

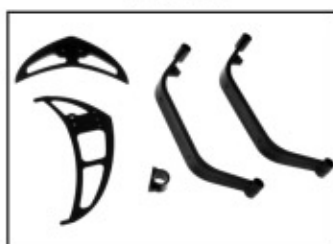

Tail Fins & Landing Mounts
TGH0208

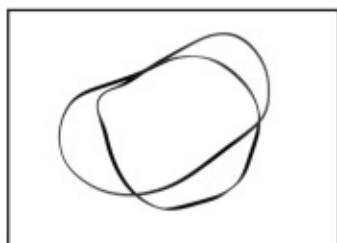

Main Belt
TGH0209



Blade Holder
TGH0210



Tail Blade Controlling Set
TGH0211



Bearing Block
TGH0212

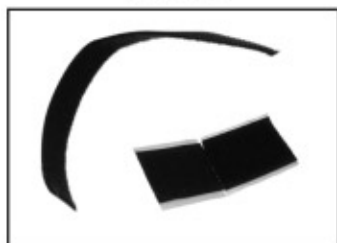

Hook & Loop Tape
TGH0213

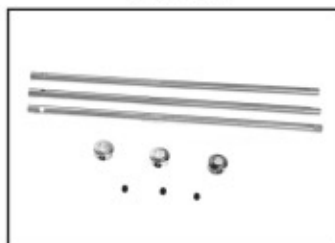

Main Shaft & Tail Blade Shaft
TGH0214

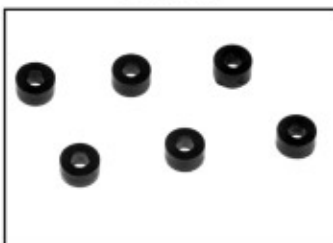

O-Ring
TGH0215



Tail Blade Clamp Set
TGH0216

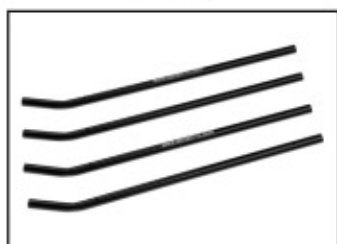

Landing Skids
TGH0217



Tail Boom
TGH0218



Main Blade Clamp Set
TGH0219

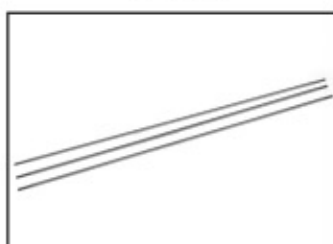

Fly Bar
TGH0220



Tail Blade Main Shaft Set
TGH0221



Main Blade Housing
TGH0222



Seesaw
TGH0223

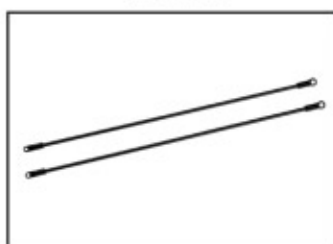

Tail Driven Pedestal Set
TGH0224

PARTS LISTING

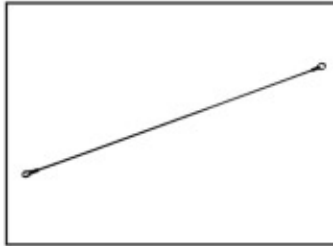

Tail Servo Control Push Rod
TGH0225

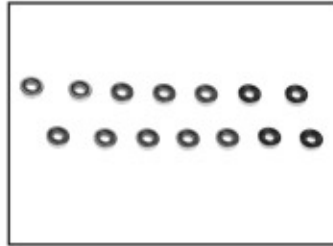

Bearing 1.5x4x1.1mm
TGH0226

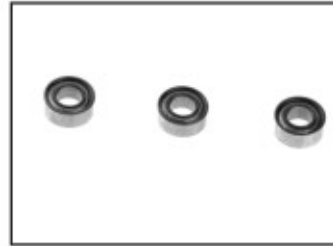

Bearing 3x6x2.5mm
TGH0227

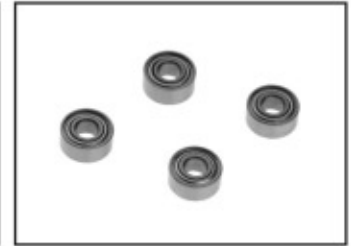

Bearing 2.5x6x2.6mm
TGH0228

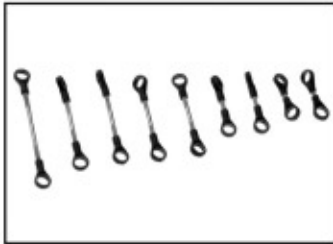

Connecting Rod
TGH0229



One Way Bearing
TGH0230

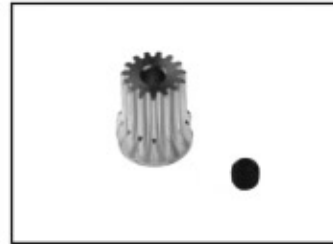

Motor Gear
TGH0231



Washout Base Set
TGH0232



Tail Rotor Housing
TGH0233



Washout Control Arm
TGH0234



Motor Mount Set
TGH0235



Feathering Shaft Set
TGH0236



Swash Plate Set
TGH0237



SF-Arm Set
TGH0238

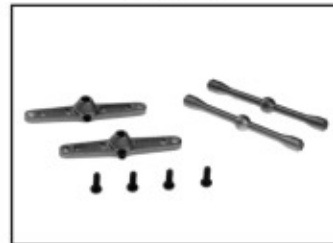

Flay Bar Caddles
TGH0239

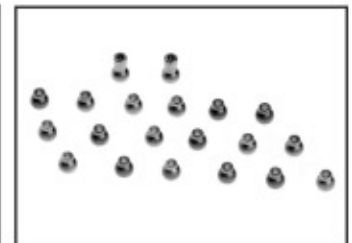

Linkage Ball
TGH0240



1.5mm Screw Set
TGH0441

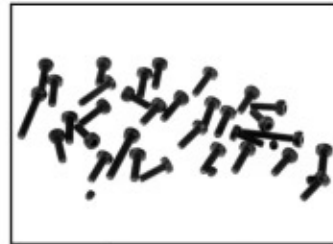

2mm screw set
TGH0442

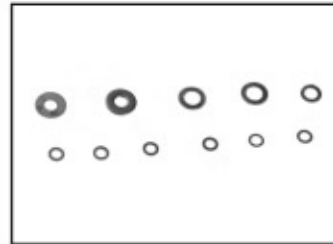

Washers
TGH0243



Complete Head System
TGH0244



Hexagon Screw Driver & Lock
TGH0245



Brushless Motor
TGH0531



Micro Gyro
ET0080



15 Amp ESC
ET0148

PARTS LISTING



Balance Charger
TGP0516



7g Micro Servo
TGP0504



7.4v 850mah 15C Lipo
TGP0518



Fibreglass 250 Painted Canopy
TGH0246

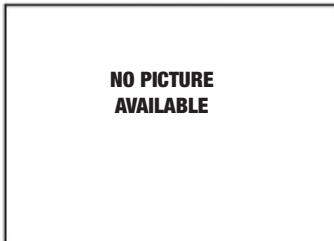

205mm Carbon Fibre Blades (opt)
TGH0270



205mm Fibreglass Blades
TGH0247



6ch 2.4ghz Transmitter
TGP0513

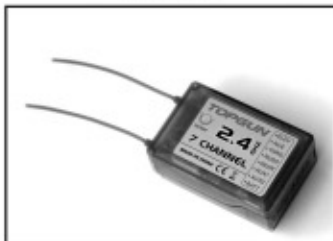

6ch 2.4ghz Receiver
TGP563



IMPORTANT SAFETY INSTRUCTIONS AND WARNINGS – READ BEFORE USE

- Lithium Polymer batteries can be volatile. Whilst some of the instances listed below are rare, they can occur and it is important for you to be aware of how to handle such situations. Failure to read and follow the below instructions may result in fire, personal injury and damage to property if charged or used improperly.
- Top Gun Heli Pro, its distributors or retailers assume no liability for failures to comply with these warnings and safety guidelines.
- By using this battery, the buyer assumes all risks associated with lithium batteries. If you do not agree with these conditions, return the battery immediately before use.
- The final use and preparation of the battery pack is ultimately beyond our control and those of our representatives and retailers. Your decision to use this product incorporates your agreement that you have read and understood the safety precautions listed below and on each battery pack, and that you agree to accept full responsibility for any injury, loss or damage resulting from all circumstances surrounding your use or misuse of this product.

GENERAL GUIDELINES AND WARNINGS

- 1) Only use the supplied specific Lithium Polymer charger. Do not use a NiMH or NiCd charger - Failure to do so may cause fire, which may result in personal injury and property damage.
- 2) Never charge batteries unattended. When charging LiPo batteries you should always remain in constant observation to monitor the charging process and react to potential problems that may occur.
- 4) If at any time you witness a battery starting to balloon or swell up, discontinue charging process immediately, disconnect the battery and observe it in a safe place for approximately 15 minutes. This may cause the battery to leak, and the reaction with air may cause the chemicals to ignite, resulting in fire.
- 5) Since delayed chemical reaction can occur, it is best to observe the battery as a safety precaution. Battery observation should occur in a safe area outside of any building or vehicle and away from any combustible material.
- 6) Wire lead shorts can cause fire! If you accidentally short the wires, the battery must be placed in a safe area for observation for approximately 15 minutes. Additionally, if a short occurs and contact is made with metal (such as rings on your hand), severe injuries may occur due to the conductivity of electric current.
- 7) A battery can still ignite even after 10 minutes.
- 8) In the event of a crash, you must remove battery for observation and place in a safe open area away from any combustible material for approximately 15 minutes.
- 11) Never store or charge battery pack inside your car in extreme temperatures, since extreme temperature could ignite fire.

CHARGING PROCESS

- 1) Never charge batteries unattended.
- 2) Charge in an isolated area, preferably inside a tin and away from other flammable materials.
- 3) Let battery cool down to ambient temperature before charging.

DISCHARGE

Ensure that you adhere to the warning beeps on your transmitter and land the model accordingly. Do not fly until the battery is completely discharged as damage will occur.

STORAGE & TRANSPORTATION

- 1) Store battery at room temperature between 40 and 80 degrees F for best results.
- 2) Do not expose battery pack to direct sunlight (heat) for extended periods.
- 3) When transporting or temporarily storing in a vehicle, temperature range should be greater than 20 degrees F but no more than 150 degrees F.
- 4) Storing battery at temperatures greater than 170 degrees F for extended periods of time (more than 2 hours) may cause damage to battery and possible fire.

BATTERY LIFE

Batteries that lose 20% of their capacity must be removed from service and disposed of properly. Discharge the battery to 3V/Cell, making sure output wires are insulated, then wrap battery in a bag for disposal.

PRODUCT WARRANTY

Product warranty is limited to original defects in material and workmanship. Warranty does not cover collateral damage. Due to the nature and use of the battery there is no term warranty. Misuse, abuse, incorrect charging and other inappropriate use of this product are not covered under warranty.

Exploded view(front)

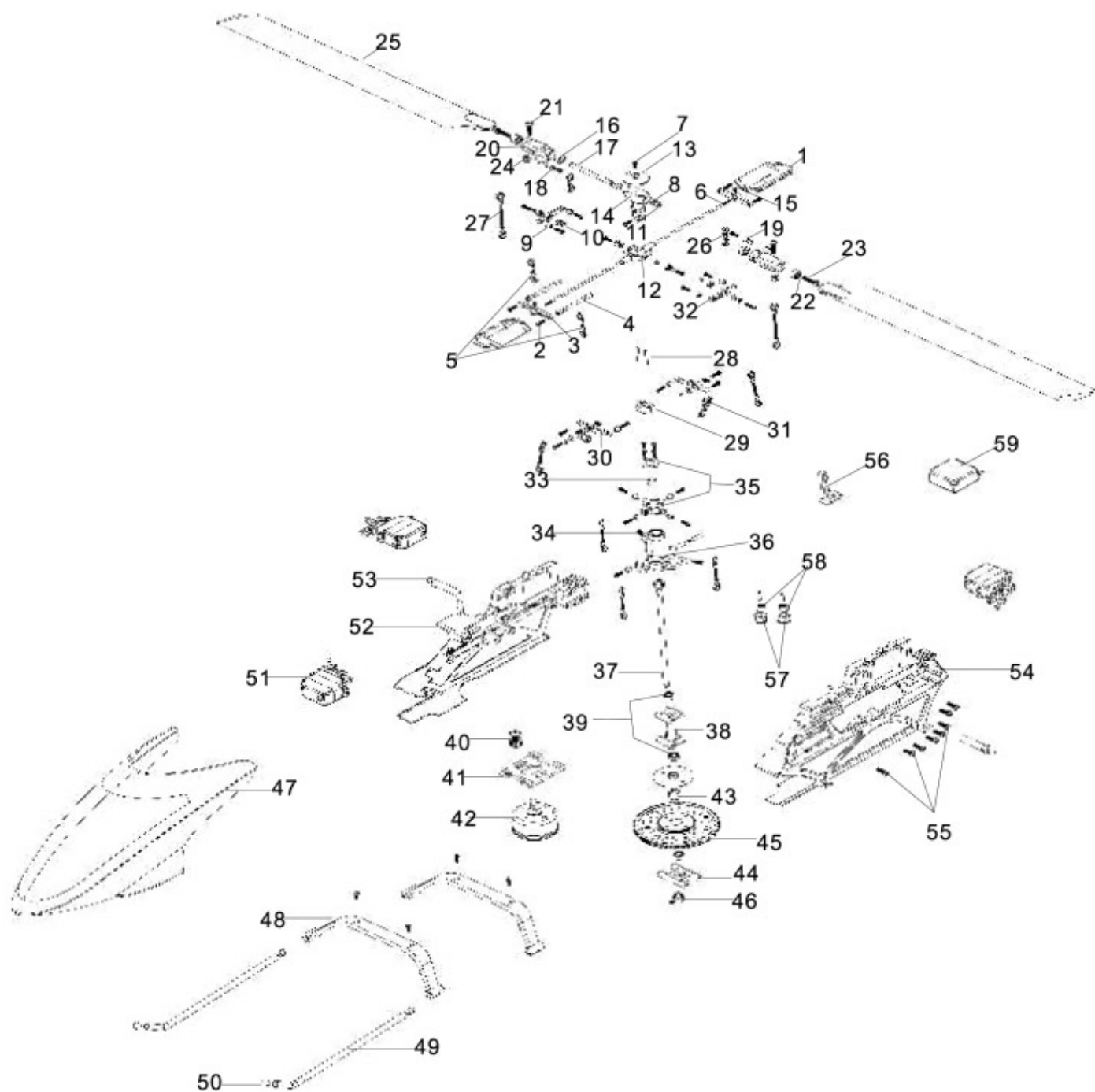

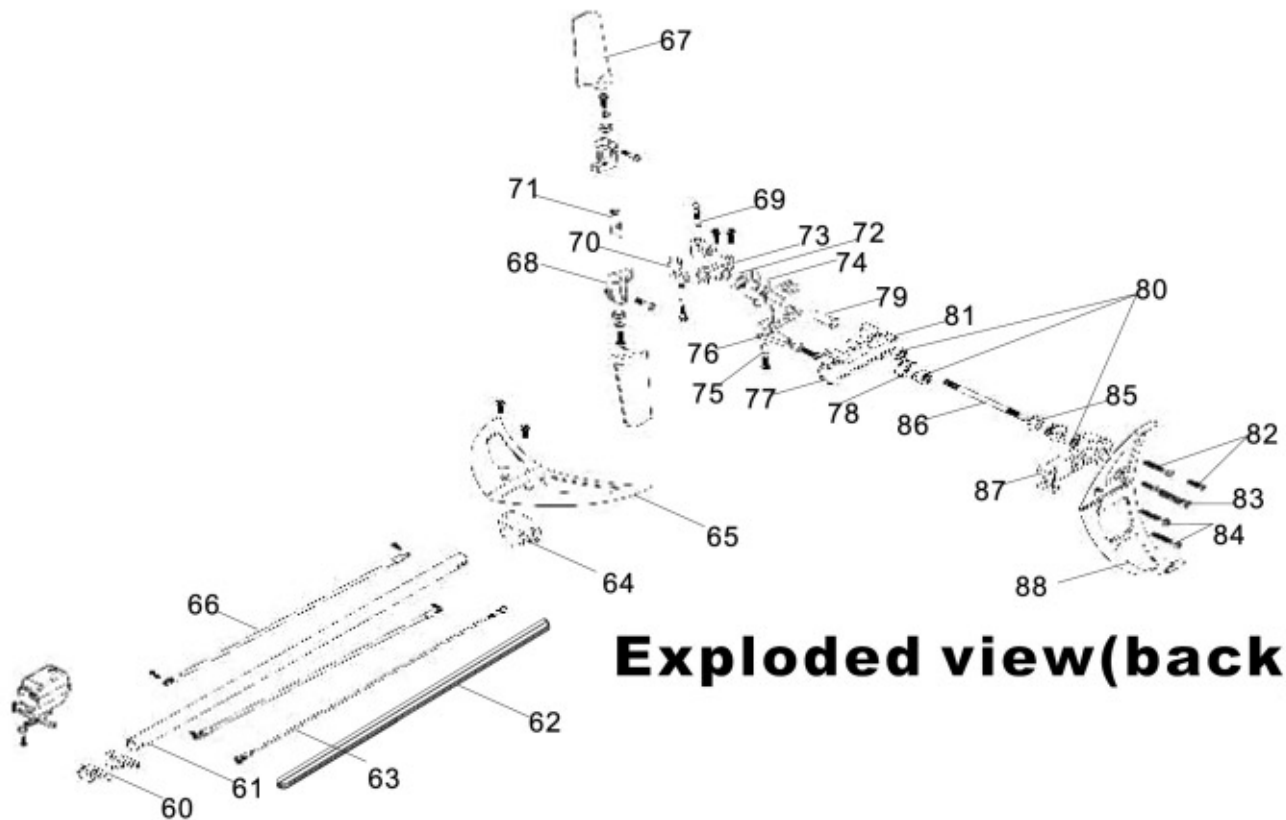

Exploded view(back)

- | | | |
|---|--|---|
| 1. Fly bar paddle | 30. Stabilizer control lever arm | 60. Tail servo mount |
| 2. Cross screw | 31. Stabilizer control arm connecting part | 61. Tail boom |
| 3. Mount arm | 32. Washout control arm | 62. Belt |
| 4. Ball part connection part | 33. Swash plate control ball | 63. Tail servo linkage rob |
| 5. Linkage rod of washout control arm and fly bar caddles | 34. Bearing $\phi 6$ | 64. Horizontal stabilizer bracket |
| 6. Fly bar | 35. Inner swash plate ring | 65. Horizontal stabilizer |
| 7. Socket screw M1.5x4 | 36. Outer swash plate ring | 66. Brace rod |
| 8. O shape circle | 37. Main shaft | 67. Tail rotor |
| 9. Ball part | 38. Main shaft bearing mount(up) | 68. Tail rotor holder |
| 10. Washer $\phi 1.6 \times 2.7 \times 0.3$ | 39. Certripetal bearing 3x6x2.5 | 69. Copper ring $\phi 1.5 \times 2.4 \times 6$ |
| 11. Washer | 40. Motor gear | 70. Tail control lever |
| 12. Flybar seesaw holder | 41. Motor mount | 71. Tail rotor housing |
| 13. Brake plate | 42. Brushless motor | 72. Bearing 3x6x2.5 |
| 14. Main rotor housing | 43. One way bearing 3x6x2.5 | 73. Tail pusher |
| 15. Set screw | 44. Main shaft bearing mount(down) | 74. Swing ring |
| 16. Bearing 2.5x6x3 | 45. Main gear | 75. Copper ring $\phi 2 \times 2.75 \times 4.8$ |
| 17. Main rotor feathering shaft | 46. Main shaft mount aluminum ring | 76. Tail pitch fork |
| 18. Cross screw | 47. Canopy | 77. Belt wheel |
| 19. Ball part | 48. Landing skid | 78. Belt wheel set |
| 20. Main blade grip | 49. Landing skid aluminum pipe | 79. Copper sliver |
| 21. Socket screw M2x10 | 50. Skid pipe cover | 80. Bearing 2x5x2.5 |
| 22. Feathering shaft copper washers | 51. Micro servos | 81. Tail case right |
| 23. Socket screw M2x6 | 52. Main frame(right) | 82. Socket screw M1.5x8 |
| 24. Nylon nut | 53. Canopy mount part | 83. Socket screw M2x10 |
| 25. Main rotor blade | 54. Main frame(left) | 84. Socket screw M1.5x10 |
| 26. Linkage rod of main blade grips and sf-arm | 55. Socket screw M2x6 | 85. Tail belt wheel |
| 27. Linkage rod of swash plate and sf-arm | 56. Swash plate anti rotation bracket | 86. Tail feathering shaft |
| 28. Washout case mounting heedle | 57. Belt wheel set | 87. Tail case left |
| 29. Washout base | 58. Bearing 2x5x2.5 | 88. Vertical stabilizer |
| | 59. Gyro | |

Rapier 250

ELECTRIC POWERED 6 CHANNEL RTF RC HELICOPTER



DISTRIBUTORS OF QUALITY MODEL & HOBBY PRODUCTS

Saxon House, Saxon Business Park, Hanbury Road, Bromsgrove, Worcestershire. B60 4AD. England

Tel: +44 (0) 1527 575349 Fax: + 44 (0) 1527 570536

E-mail: info@cmldistribution.co.uk

Web site: www.cmldistribution.co.uk